

Tank Truck Top Loading Data Sheet

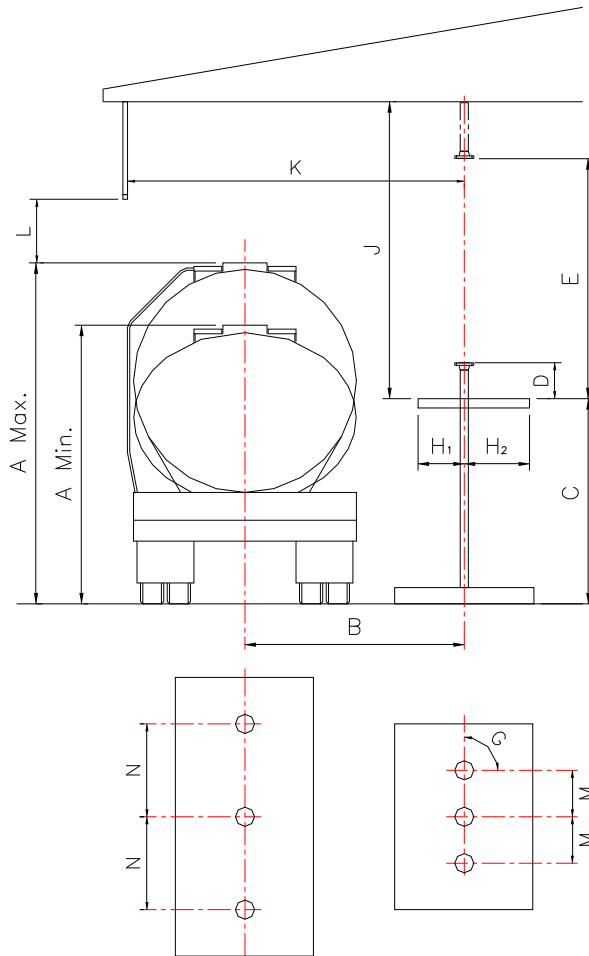

SKETCH AREA

Loader Style _____ .Size _____ .

A) Truck Height Max _____ .Min _____ .

B) Reach _____ .

C) Platform Height _____ .

D) Riser Height from Platform _____ .

E) Riser Downfeed Height from Platform _____ .

F) Type of Riser Connection _____ .

G) Loader Base Clearance Rad _____ .

H) Center to Platform Edge Max _____ .Min _____ .

J) Canopy Height from Platform _____ .

K) Safety Rail to Riser Center _____ .

L) Safety Rail to Tank Truck Max _____ .Min _____ .

M) Riser Centers _____ .

N) Fill Centers _____ .

Loader Drop Pipe Length C.L to End _____ .

Type of Drop Pipe End :

- Deflector _____ .

- 45 W/F Protector _____ .

- Straight W/F Protector _____ .

- Wet Line _____ .

- Dry Line _____ .

Extension Control Yes _____ .No _____ .

Product	Temp. Range F
1 _____ .	_____ .
2 _____ .	_____ .
3 _____ .	_____ .
4 _____ .	_____ .

Line Pressure _____ PS.I

Flow Rate _____ .