

## Bottom Loading Systems

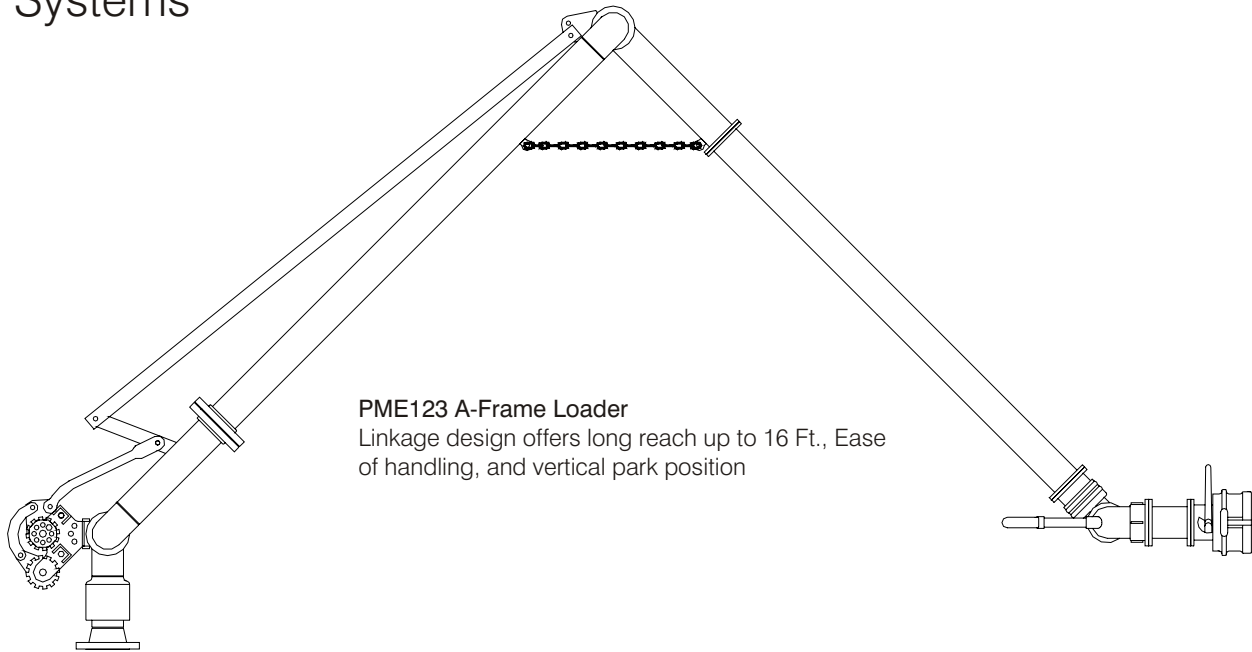

**PME123 A-Frame Loader**  
Linkage design offers long reach up to 16 Ft., Ease of handling, and vertical park position

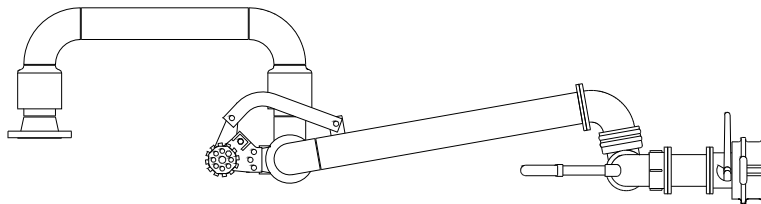

**PME033 Bottom Transfer**  
Recommended when loading arm height is restricted. Used for aviation refuellers, railcar and chemical transport.

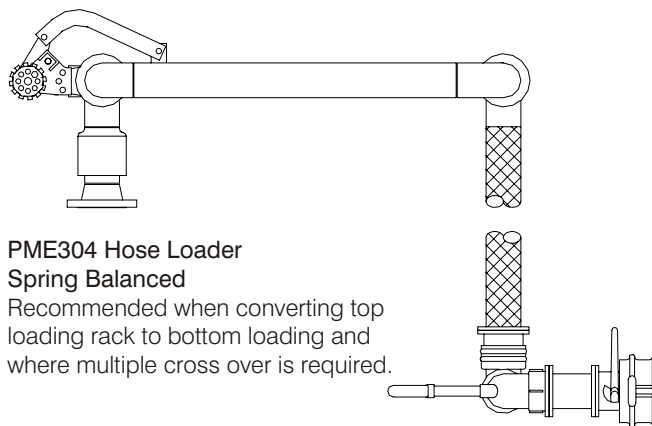

**PME304 Hose Loader**  
**Spring Balanced**  
Recommended when converting top loading rack to bottom loading and where multiple cross over is required.

---

**P M SYSTEMS LIMITED**

6890 DAVAND DRIVE, MISSISSAUGA, ONTARIO, CANADA, L5T-1J5

Phone: (905) 670-8453, 1-800-405-1203 Fax: (905) 564-2966 Web: [www.pmsystems.on.ca](http://www.pmsystems.on.ca)

# Top Loading Systems

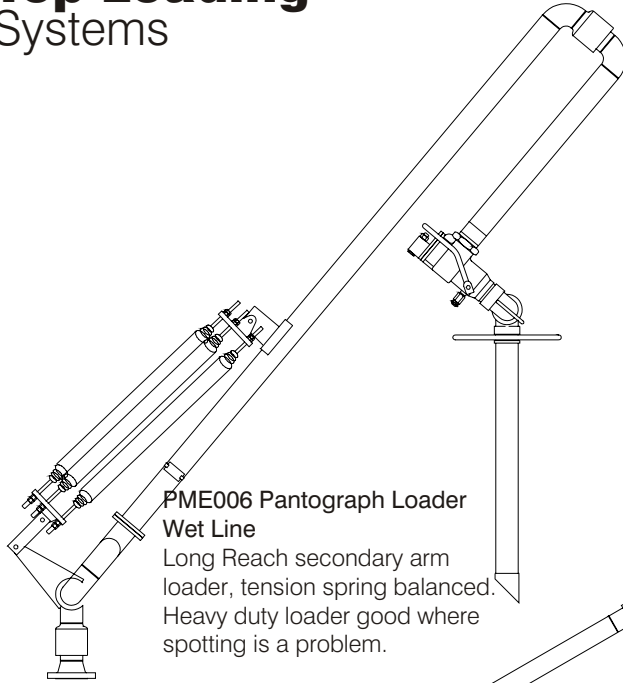

**PME006 Pantograph Loader Wet Line**  
Long Reach secondary arm loader, tension spring balanced. Heavy duty loader good where spotting is a problem.

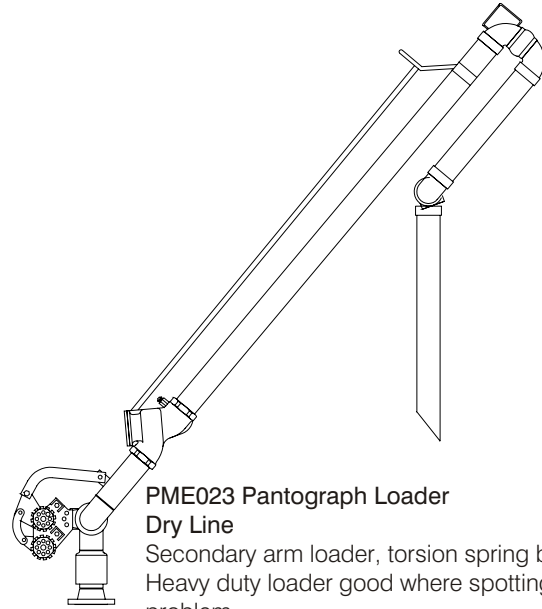

**PME023 Pantograph Loader Dry Line**  
Secondary arm loader, torsion spring balanced. Heavy duty loader good where spotting is a problem.

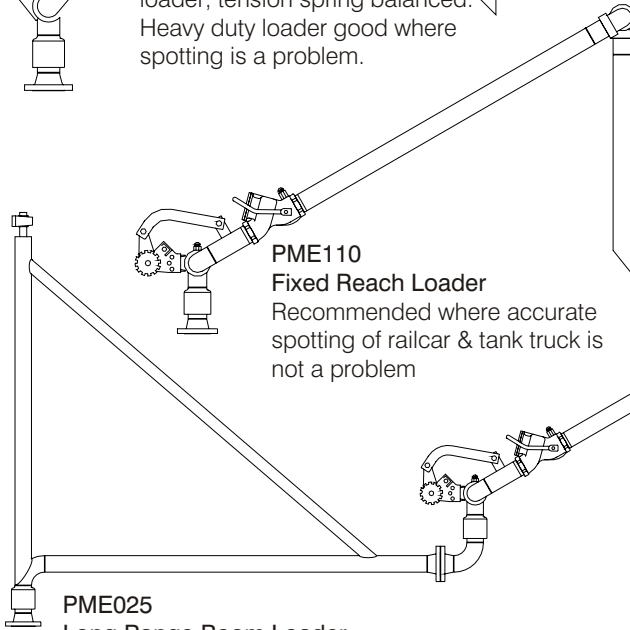

**PME110 Fixed Reach Loader**  
Recommended where accurate spotting of railcar & tank truck is not a problem

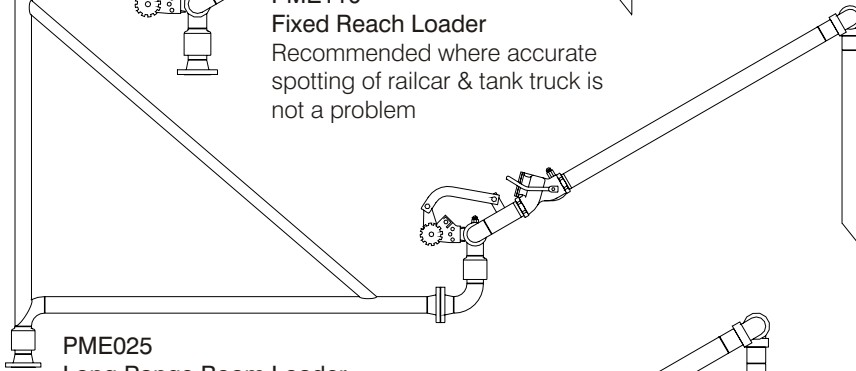

**PME025 Long Range Boom Loader**  
Recommended for extended reach requirements  
Maximum reach of 15'-6"

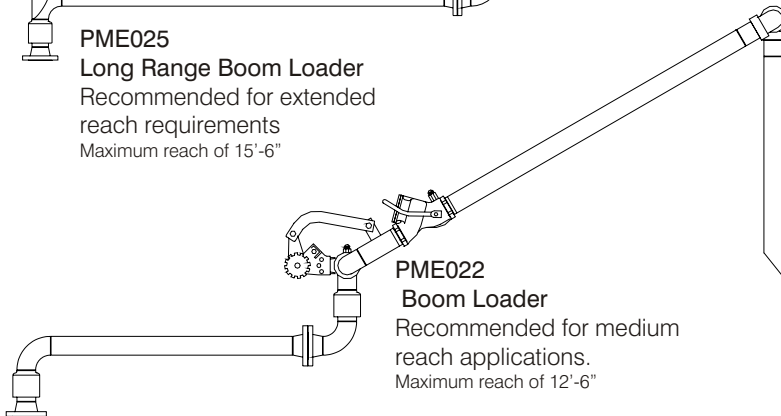

**PME022 Boom Loader**  
Recommended for medium reach applications.  
Maximum reach of 12'-6"

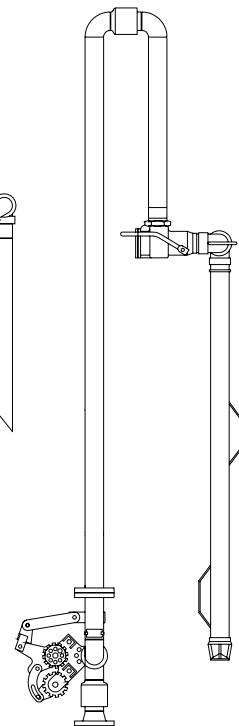

**PME115 Wet Line Loader**

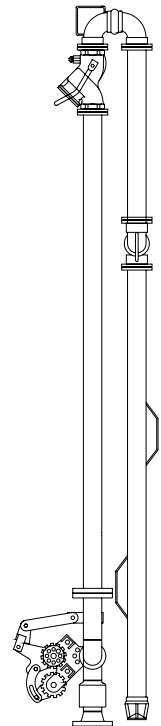

**PME015 Dry Line Loader**

**Vertical Park Loaders**  
Recommended where spacing is tight between risers and both sides of rack is serviced.

**P M SYSTEMS LIMITED**

6890 DAVAND DRIVE, MISSISSAUGA, ONTARIO, CANADA, L5T-1J5

Phone: (905) 670-8453, 1-800-405-1203 Fax: (905) 564-2966 Web: [www.pmsystems.on.ca](http://www.pmsystems.on.ca)

## Speciality Loading Systems

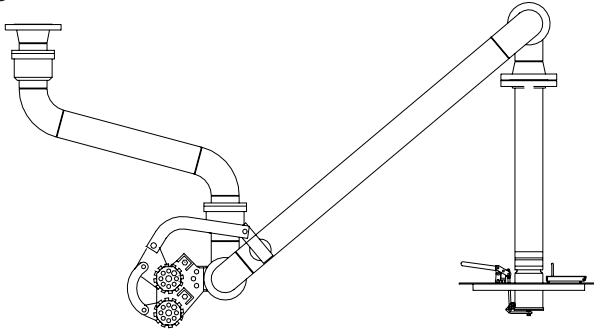

### PMES01 Boom Loader

Loader made of stainless steel with special seals for chemical or food grade applications.

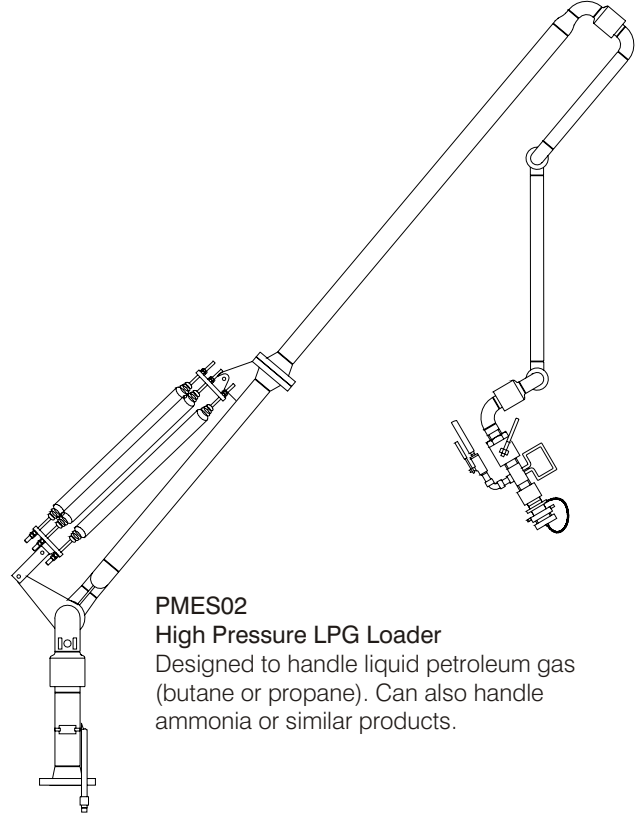

### PMES02 High Pressure LPG Loader

Designed to handle liquid petroleum gas (butane or propane). Can also handle ammonia or similar products.

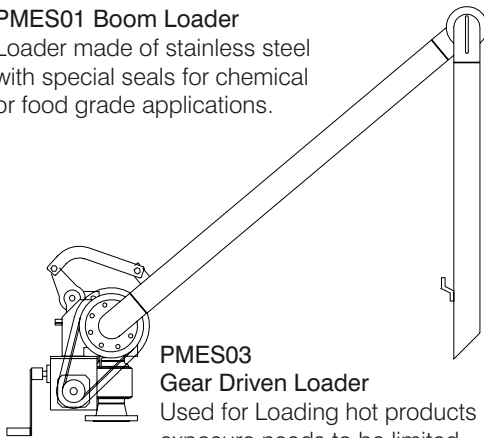

### PMES03 Gear Driven Loader

Used for Loading hot products or products where exposure needs to be limited. Loader can be cranked down for loading which holds loader in position.

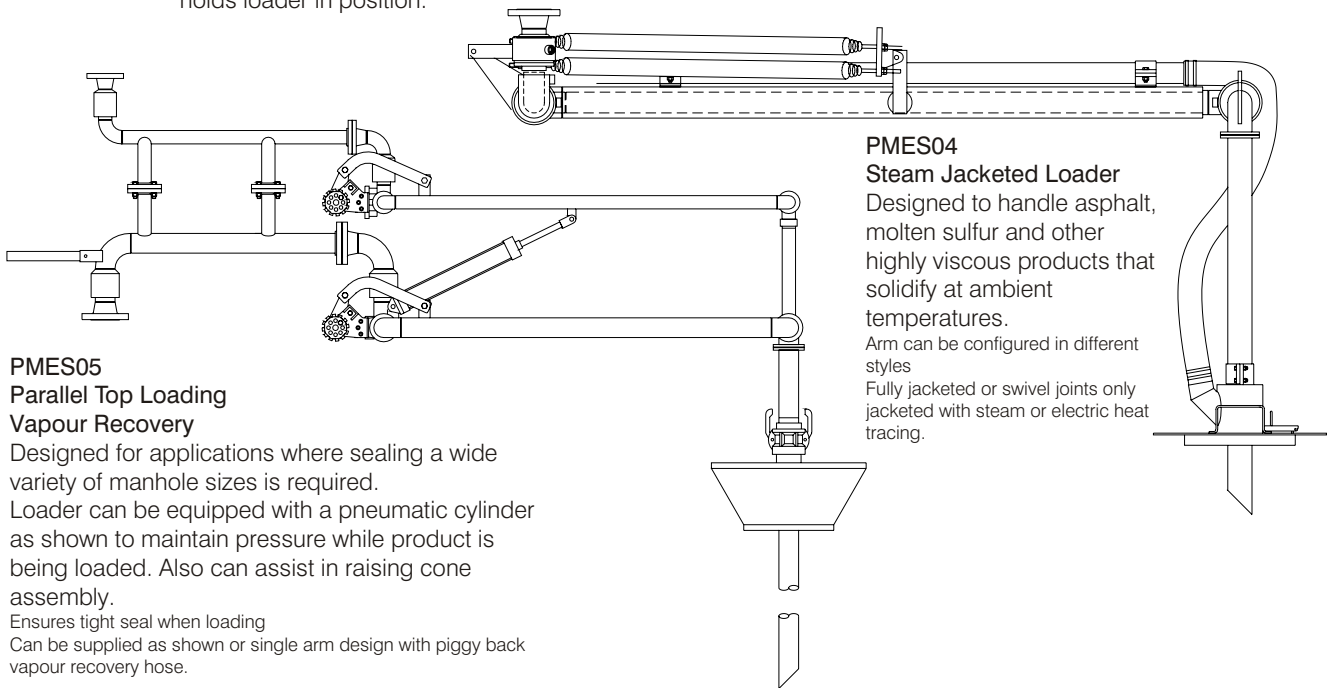

### PMES04 Steam Jacketed Loader

Designed to handle asphalt, molten sulfur and other highly viscous products that solidify at ambient temperatures.

Arm can be configured in different styles  
Fully jacketed or swivel joints only jacketed with steam or electric heat tracing.

### PMES05 Parallel Top Loading Vapour Recovery

Designed for applications where sealing a wide variety of manhole sizes is required. Loader can be equipped with a pneumatic cylinder as shown to maintain pressure while product is being loaded. Also can assist in raising cone assembly.  
Ensures tight seal when loading  
Can be supplied as shown or single arm design with piggy back vapour recovery hose.

## P M SYSTEMS LIMITED

6890 DAVAND DRIVE, MISSISSAUGA, ONTARIO, CANADA, L5T-1J5

Phone: (905) 670-8453, 1-800-405-1203 Fax: (905) 564-2966 Web: [www.pmsystems.on.ca](http://www.pmsystems.on.ca)